

RTY 01-10

Rooftop

Cooling capacity 30,2 ÷ 133,6 kW
 Heating capacity 29,3 ÷ 137,9 kW

- Handling section with plug fans coupled with brushless EC motors
- Thermodynamic heat recovery
- Free-cooling operation
- For high crowding applications



Independent Roof-top type air conditioner for treatment, filtration and renewal of the air, based on the chosen configuration. RTY units are designed for high crowding applications, such as cinemas, conference rooms, restaurants, nightclubs being intended for operation with 80% external and expelled air.

The standard unit allows to manage the cooling operation and the recovery of the energy contained in the exhaust air allowing higher performances and efficiencies.

VERSIONS

RTY_H heat pumps

CONFIGURATIONS

MB3 with mixing chamber with three dampers, return fan and heat recovery from expelled air.

The configuration can be further customized with a wide choice of accessories

- 1 refrigerant circuit
- High efficiency scroll compressors (tandem UNEVEN) and low power consumption
- Finned exchangers of the refrigerant circuit direct expansion.
- Supply and return fans, of plug fan type (EC). The impellers are so oriented to ensure that the air flow passes through all the internal components, with the minimum noise.
- Group of axial fans for extremely silent operation placed on the condensing section.
- Electronic control of condensation and evaporation are standard to extend further the operating limits of the unit.
- G4 air filter on the flow of outside air and on the recovery; they are installed upstream of the components, to ensure low pressure drops.

CONTROL

Microprocessor control can handle the different modes of operation ensuring maximum energy savings in any conditions C

Interfaces for connections to remote control supervision system, available as optional.

ACCESSORIES AND FITTINGS

- SSV:** Supervision system
- RS:** Serial card BMS RS485
- LW:** Interface card LonWorks
- BIP:** Interface card Ethernet-pCOWeb (BACNET IP)
- BAC:** interface card BACnet MS/TP pCOnet
- FTH:** Enthalpic free-cooling
- PSTEP:** Adjusting constant flow, step flow in function of the modulation of the cooling circuit
- FT7:** pocket filters F7 efficiency placed on the flow of supply air.
- FT9:** Pocket filters F9 efficiency placed on the flow of supply air
- H10:** Electronic filters placed on the flow of supply air.
- PSF2:** Differential pressure switch signaling fouled filters of recovery, renewal and discharge
- Gx:** Heating module with gas burner
- BW:** 2-rows heating coil with hot water
- BWV2V:** 2-rows heating coil with hot water, with 2-way modulating valve.
- BWV3V:** 2-rows heating coil with hot water, with 3-way modulating valve.
- BE:** Electric heating coil 2 stages (**not available with hot air generator**)
- BEM:** Modulating electric heating coil (**not available with hot air generator**)
- BPGC:** After heating coil with hot gas .
- AXEC:** Axial fans with EC motors with speed control function according to the pressure of condensation and evaporation.
- MAN:** High and low pressure gauges
- U:** installed steam ramp
- UP:** Immersed electrode producer standard supplied and installed steam ramp
- CUR:** Humidification control (Humidity probe in recovery , limit humidity probe in supply, contact ON/OFF and modulating analog output)
- DP:** Dehumidification control (humidity probe in recovery) and of after-heating (if present)
- SCO2:** Probe CO2
- SVOC:** Probe VOC
- STA:** Room temperature probe
- SUA:** Room humidity probe

- RF:** Smoke detector
- RFC:** Smoke detector and recirculation damper closure management and external air intake
- PR1:** Remote control panel
- SCMRM:** Modulating servo-controls with spring return
- CA:** Waterproof headphones on external air intake
- CF:** Flue pipe (only on version with gas burner module)

- GP:** Protection grille for external coils
- VT:** antivibration mounts
- MSSM:** Delivery silencers forms (only for rear air delivery)
- MSSR:** Recovery silencers forms (only for rear air delivery)

■ *NOTE: for more details on accessories and equipment, please refer to the technical handbook.*

FEATURES AND TECHNOLOGICAL ADVANTAGES

RTY units have been designed with the aim of reducing energy consumption that dictated the result of technological choices present on the unit that we briefly present.

HIGH EFFICIENCY VENTILATION

Ventilation is one of the major factors of power consumption, for this reason particular attention has been given to the study and the construction of the ventilation system.

Fans type plug-fans with brushless EC motors have been used in both supply and recovery; they enable high performances and low power consumption; also comparing them to conventional centrifugal fans, they have no belts or pulleys allowing easy flow regulation, compactness, versatility and ease of maintenance.

A particular adaptive logic allows to adjust the air flow to the actual demand of the system with more consequent advantages in terms of reduction of consumption.

Axial fans for the external section of the unit are of helical type; the electronic control of condensation is standard and it regulates the fan speed according to the load required, allowing a noise reduction.

As an option, the motors can be electronically controlled (EC) for the reduction in consumption of the condenser section.

MAXIMUM SEASONAL EFFICIENCIES

To improve the efficiency of the refrigerant circuit, we have used scroll tandem compressors with different power between them (compressors UN-EVEN except for size 08. This feature allows a reduction of consumptions and a better adaptability to the demands of the system, especially in the operation at partial loads, ensuring higher seasonal efficiency.

AIR QUALITY IN THE ROOM

Particular attention has been given naturally also to the quality of air in the room, **entrusted to the standard filters with G4 efficiency on the flow of outside air, also available on the recovery (optional) for process applications.**

They are also available as an (optional) compact filters F7 and F9 or electronic H10 on the flow of fresh air.

ACTIVE THERMODYNAMIC RECOVERY

It is also available a thermodynamic recovery for the recovery of the energy contained in the exhaust air in such a way that the flow of exhaust air invests the external finned heat exchanger, allowing higher performances and efficiencies.

Of course all these technological advantages are controlled by a temperature control of the latest generation, able to handle the different modes of operation; ensuring maximum energy savings in all operating conditions by means of a special software.

CONFIGURATION WITH THERMODYNAMIC RECOVERY "MB3"

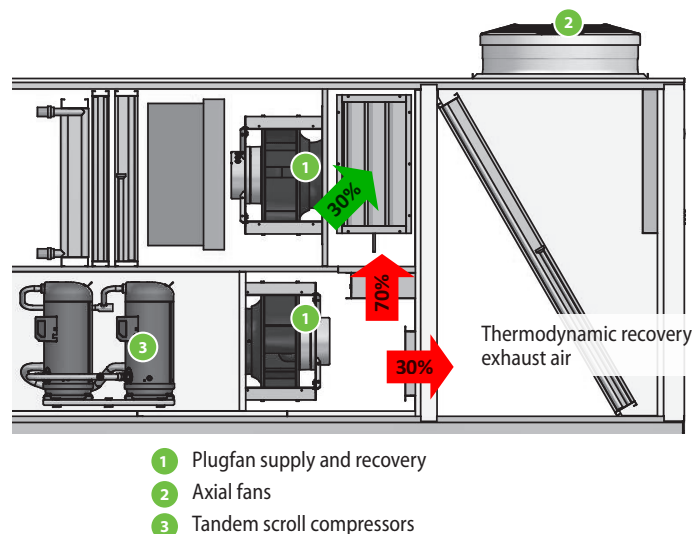

PERFORMANCE SPECIFICATIONS

Mod. RTY Heat pump

Size		01	02	03	04	05	06	07	08	09	10
Cooling capacity	(1) kW	30,2	39,6	48,7	65,4	75,3	84,3	90,9	107,6	121,4	133,6
Sensitive cooling capacity	kW	21,2	27,1	32,6	43,1	48,9	55,2	61,1	70,5	80,6	87,4
Sensitive / total cooling power	kW	0,70	0,68	0,67	0,66	0,65	0,66	0,67	0,66	0,66	0,65
Compressor input power	kW	5,3	8,4	9,7	13,1	15,2	17,5	18,5	23,3	27,6	32,6
EER	W/W	5,70	4,71	5,00	5,00	4,96	4,82	4,92	4,61	4,39	4,09
EER global	W/W	4,63	4,02	3,86	3,54	3,54	3,44	3,41	3,33	3,20	3,01
Heating capacity	(2) kW	29,3	39,7	48,5	66,5	76,6	85,8	91,4	110,4	123,4	137,9
Compressor input power	kW	4,4	7,0	8,4	12,4	14,2	15,7	15,5	19,2	21,8	25,5
COP	W/W	6,67	5,68	5,77	5,38	5,39	5,47	5,89	5,73	5,66	5,41
COP global	W/W	5,21	4,70	4,30	3,75	3,78	3,77	3,85	3,91	3,84	3,70

(1) Internal temperature 27°C d.b., 19°C w.b.; External temperature 35°C d.b., 24°C w.b.; U.R. 40%;

(2) Internal temperature 20°C d.b., 15°C w.b.; External temperature 7°C d.b. 6°C w.b.;

GENERAL TECHNICAL DATA

Size		01	02	03	04	05	06	07	08	09	10	
Compressors												
Compressors	type	Scroll										
	n°	2	2	2	2	2	2	2	2	2	2	
Circuits	n°	1	1	1	1	1	1	1	1	1	1	
Capacity steps	(1) %	3	3	3	3	3	3	3	2	3	3	
Refrigerant gas	type	R410A										
Fans												
External fans	type	Axials AC										
	n°	1	1	2	2	2	2	2	2	2	2	
Internal fans of flow	type	RAD EC										
	n°	1	1	1	1	1	1	1	1	1	2	
	Ø mm	400	450	450	450	450	450	500	500	560	630	
Internal fans of recovery	type	RAD EC										
	n°	1	1	1	1	1	1	1	1	2	2	
	Ø mm	400	450	450	450	450	500	500	450	450	450	
Air flow of inside fan	nom/max	m³/h	3500	4500	5500	7000	8000	9500	11500	14000	15000	16500
	min	m³/h	2450	3150	3850	4900	5600	6650	8050	9800	10500	11550
Available static pressure of supply	(2) max	Pa	150	150	200	200	200	250	250	300	300	
Available static pressure of recovery	(2) max	Pa	171	184	248	235	245	311	336	372	439	
Power supply	V/ph/Hz	400V/3/50Hz										

(1) Sizes 08 don't have UNEVEN compressors

(2) At the nominal/maximum flow rate, G4 medium fouling filter

Sound pressure: Sound pressure measured in free field, (1m, Q=2) away from the external surface of the ducted unit, available static pressure 300Pa at a nominal flow (in accordance with the UNI EN ISO 3744).

Note: For more informations please refer to the technical documentation available on the website www.aermec.com

DIMENSIONS

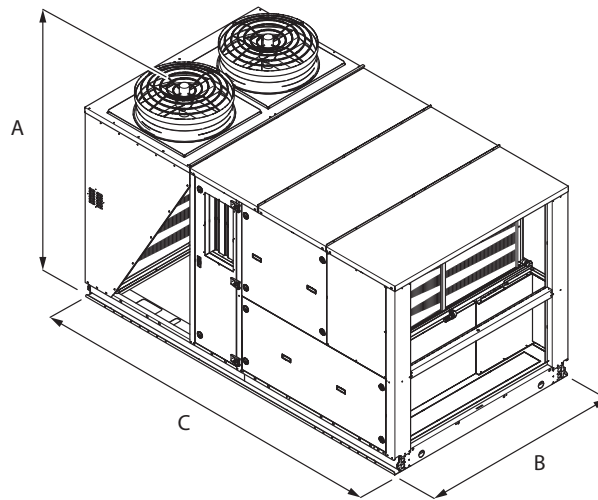

Size		Vers.	01	02	03	04	05	06	07	08	09	10
Dimensions												
A	mm	All	2061	2061	2061	2373	2373	2373	2373	2373	2373	2373
B	mm	All	1900	1900	1900	2100	2100	2100	2100	2100	2100	2100
C	mm	All	3400	3400	3400	3400	3400	3400	3400	3400	3400	3400

Aermec reserves the right to make any modifications deemed necessary.
All data is subject to change without notice. Aermec does not assume
responsibility or liability for errors or omissions.

Aermec S.p.A.
Via Roma, 996 - 37040 Bevilacqua (VR) - Italia
Tel. 0442633111 - Telefax 044293577
www.aermec.com