

NRL 0280-0750

Air-water chiller

Cooling capacity 56 ÷ 194 kW

- Low noise levels in silenced versions
- High efficiency also at partial loads
- Night mode
- Compact dimensions



DESCRIPTION

Air-cooled outdoor chiller designed to meet air conditioning needs in residential/commercial complexes or industrial applications. The base the structure and the panels are made of steel treated with polyester paint RAL 9003.

VERSIONS

- A** High efficiency
- E** Silenced high efficiency

FEATURES

Operating field

Operation at full load up to 46 °C external air temperature. Unit can produce chilled water (up to -10°C of water produced in some versions).

Dual-circuit unit

The units according to the size are mono or dual-circuit, to ensure maximum efficiency both at full load and at partial load.

Electronic expansion valve

The possibility to use electronic expansion valve, available to configurator, offers significant benefits, especially when the chiller is working with partial loads, increasing the energy efficiency of the unit.

Integrated hydronic kit

Integrated hydronic kit containing the main hydraulic components; available with various configurations with one or two pumps, with high or low head and storage tank, to obtain a solution that allows you to save money and to facilitate installation.

CONTROL

Microprocessor adjustment, with keyboard and LCD display, for easy access on the unit is a menu available in several languages.

- The presence of a programmable timer allows functioning time periods and a possible second set-point to be set.
- The temperature control takes place with the integral proportional logic, based on the water output temperature.
- **Night Mode:** it is possible to set a silenced operation profile. Perfect for night operation since it guarantees greater acoustic comfort

in the evenings, and a high efficiency in the time of greater load. **Night Mode for standard versions is mandatory DCPX accessory (standard on all low noise versions) or "J" inverter fan**

ACCESSORIES

AER485P1: RS-485 interface for supervision systems with MODBUS protocol.

AERNET: The device allows the control, the management and the remote monitoring of a Chiller with a PC, smartphone or tablet using Cloud connection. AERNET works as Master while every unit connected is configured as Slave (max. 6 unit); also, with a simple click is possible to save a log file with all the connected unit datas in the personal terminal for post analysis.

MULTICHILLER_EVO: Control, switch-on and switch-off system of the single chillers where multiple units are installed in parallel, always ensuring constant flow rate to the evaporators.

PGD1: Allows you to control the unit at a distance.

DCPX: Device for condensation temperature control, with continuous speed modulation of fans by using a pressure transducer.

GP: Anti-intrusion grid.

VT: Anti-vibration supports.

FACTORY FITTED ACCESSORIES

DRE: Electronic device for peak current reduction.

RIF: Power factor correction. Connected in parallel to the motor allowing about 10% reduction of input current.

PRM1: It is a manual pressure switch electrically wired in series with the existing automatic high pressure switch on the compressor discharge pipe.

C-TOUCH: 7", touch screen keyboard, which allows to navigate intuitively among the various screens, allowing to modify the operating parameters and graphically view the progress of some variables in real time.

COMPATIBILITY WITH VMF SYSTEM

For more information about VMF system, refer to the dedicated documentation.

ACCESSORIES COMPATIBILITY

Model	Ver	0280	0300	0330	0350	0500	0550	0600	0650	0700	0750
AER485P1	A					*	*	*	*	*	*
	E	*	*	*	*	*	*	*	*	*	*
AERNET	A					*	*	*	*	*	*
	E	*	*	*	*	*	*	*	*	*	*
MULTICHILLER_EVO	A					*	*	*	*	*	*
	E	*	*	*	*	*	*	*	*	*	*
PGD1	A					*	*	*	*	*	*
	E	*	*	*	*	*	*	*	*	*	*

Model	Ver	0280	0300	0330	0350	0500	0550	0600	0650	0700	0750
C-TOUCH	A	*	*	*	*	*	*	*	*	*	*
	E	*	*	*	*	*	*	*	*	*	*

Condensation control temperature

Ver	0280	0300	0330	0350	0500	0550	0600	0650	0700	0750
Fans: °										
A	-	-	-	-	DCPX64	DCPX64	DCPX64	DCPX64	DCPX64	DCPX64
E	Inverter	Inverter	Inverter	Inverter	As standard	As standard	As standard	As standard	As standard	As standard
Fans: M										
A	-	-	-	-	DCPX64	DCPX64	DCPX64	DCPX64	DCPX65	DCPX65
E	DCPX63	DCPX63	DCPX63	DCPX63	As standard	As standard	As standard	As standard	As standard	As standard

The accessory cannot be fitted on the configurations indicated with -

Antivibration

Ver	0280	0300	0330	0350	0500	0550	0600	0650	0700	0750
Integrated hydronic kit: 00										
A	-	-	-	-	VT11	VT11	VT11	VT11	VT22	VT23
E	VT17	VT17	VT17	VT17	VT11	VT11	VT11	VT11	VT22	VT23
Integrated hydronic kit: 01, 02, 03, 04, 05, 06, 07, 08, 09										
A	-	-	-	-	VT11	VT11	VT11	VT11	VT22	VT23
E	VT13	VT13	VT13	VT13	VT11	VT11	VT11	VT11	VT22	VT23
Integrated hydronic kit: P1, P2, P3, P4										
A	-	-	-	-	VT11	VT11	VT11	VT11	VT22	VT23
E	VT17	VT17	VT17	VT17	VT11	VT11	VT11	VT11	VT22	VT23

The accessory cannot be fitted on the configurations indicated with -

Anti-intrusion grid

Ver	0280	0300	0330	0350	0500	0550	0600	0650	0700	0750
A	-	-	-	-	GP2 x 2 (1)	GP2 x 2 (1)	GP2 x 2 (1)	GP2 x 2 (1)	GP2 x 3 (1)	GP10 x 3 (1)
E	GP3	GP4	GP4	GP4	GP2 x 2 (1)	GP2 x 2 (1)	GP2 x 2 (1)	GP2 x 2 (1)	GP2 x 3 (1)	GP10 x 3 (1)

(1) x _ indicates the quantity to buy

The accessory cannot be fitted on the configurations indicated with -

Device for peak current reduction

Ver	0280	0300	0330	0350	0500	0550	0600	0650	0700	0750
Power supply: °										
A	-	-	-	-	DRE501 (1)	DRE551 (1)	DRE601 (1)	DRE651 (1)	DRE701 (1)	DRE751 (1)
E	DRE281 (1)	DRE301 (1)	DRE331 (1)	DRE351 (1)	DRE501 (1)	DRE551 (1)	DRE601 (1)	DRE651 (1)	DRE701 (1)	DRE751 (1)

(1) Only for supplies of 400V 3N ~ 50Hz and 400V 3 ~ 50Hz. x 2 or x 3 (if present) indicates the quantity to be ordered.

The accessory cannot be fitted on the configurations indicated with -

A grey background indicates the accessory must be assembled in the factory

Power factor correction

Ver	0280	0300	0330	0350	0500	0550	0600	0650	0700	0750
A	-	-	-	-	RIF52	RIF52	RIF53	RIF53	RIF53	RIF53
E	RIF50	RIF50	RIF50	RIF51	RIF52	RIF52	RIF53	RIF53	RIF53	RIF53

The accessory cannot be fitted on the configurations indicated with -

A grey background indicates the accessory must be assembled in the factory

CONFIGURATOR

Field	Description
1,2,3	NRL
4,5,6,7	Size 0280, 0300, 0330, 0350, 0500, 0550, 0600, 0650, 0700, 0750
8	Operating field
°	Standard mechanic thermostatic valve (1)
X	Electronic thermostatic expansion valve (1)
Y	Low temperature mechanic thermostatic valve (2)
9	Model
°	Cooling only
C	Motocondensing unit
10	Heat recovery
°	Without heat recovery
D	With desuperheater (3)
T	With total recovery
11	Version
A	High efficiency
E	Silenced high efficiency (4)
12	Coils
°	Copper-aluminium
R	Copper-copper
S	Copper-Tinned copper
V	Copper-painted aluminium
13	Fans
°	Standard (5)
J	Inverter (6)
M	Oversized (7)
14	Power supply
°	400V ~ 3 50Hz with magnet circuit breakers
1	220V~ 3 50Hz with magnet circuit breakers
15,16	Integrated hydronic kit
	Without hydronic kit
00	Without hydronic kit
	Kit with storage tank and pump/s
01	Storage tank with low head pump
02	Storage tank with low head pump + stand-by pump
03	Storage tank with high head pump
04	Storage tank with high head pump + stand-by pump
	Kit with pump/s and storage tank with holes for heaters (8)
05	Storage tank with holes for heaters and single low head pump
06	Storage tank with holes for heaters and pump low head + stand-by pump
07	Storage tank with holes for heaters and single high head pump
08	Storage tank with holes for heaters and pump high head + stand-by pump
	Double loop
09	Double loop
	Kit with pump/s
P1	Single pump low head
P2	Pump low head + stand-by pump
P3	Single pump high head
P4	Pump high head + stand-by pump

(1) Water produced from 4 °C ÷ 18 °C

(2) Water produced from 4 °C ÷ 18 °C for version "E", -10 °C for the others versions

(3) For "YT" - "ZT" - "YD" and "ZD" recovery versions, contact the headquarters; Warning: on the recovery side, a minimum input temperature of 35°C must always be guaranteed on the heat exchanger. For more information about the unit operating range, refer to the Magellano selection program

(4) The size up 0280 ÷ 0350 are only available in the silenced versions "E" with inverter fans

(5) As standard in sizes fom 0500 ÷ 0750

(6) Standard for size 0280 ÷ 0350, without useful static pressure, option for other size with useful static pressure.

(7) Available only for size from 0280 to 0350

(8) Storage tanks with holes for supplementary heaters (not provided) are sent from the factory with plastic protection caps. Before loading the system, if the installation of one or all resistances is not expected, all plastic caps must be replaced with the special caps, commonly commercially available.

PERFORMANCE SPECIFICATIONS

NRL - A

Size		0280	0300	0330	0350	0500	0550	0600	0650	0700	0750
Cooling performance 12 °C / 7 °C (1)											
Cooling capacity	kW	-	-	-	-	97,7	103,7	128,7	142,7	162,7	194,6
Input power	kW	-	-	-	-	30,7	34,8	40,8	45,4	53,3	63,3
Cooling total input current	A	-	-	-	-	55,0	60,0	71,0	77,0	90,0	113,0
EER	W/W	-	-	-	-	3,19	2,98	3,15	3,14	3,05	3,07
Water flow rate system side	l/h	-	-	-	-	16838	17868	22164	24569	28005	33503
Pressure drop system side	kPa	-	-	-	-	44	49	54	60	68	88

(1) Data 14511:2018; System side water heat exchanger 12 °C/7 °C; External air 35 °C

NRL - E

Size		0280	0300	0330	0350	0500	0550	0600	0650	0700	0750
Cooling performance 12 °C / 7 °C (1)											
Cooling capacity	kW	56,8	64,8	73,8	82,8	89,8	94,8	116,7	128,7	149,7	179,6
Input power	kW	17,1	19,7	22,1	25,5	33,5	37,1	44,9	52,3	57,4	69,2
Cooling total input current	A	30,0	34,0	37,0	45,0	60,0	64,0	78,0	89,0	97,0	120,0
EER	W/W	3,33	3,29	3,34	3,24	2,68	2,55	2,60	2,46	2,61	2,60
Water flow rate system side	l/h	9793	11168	12714	14260	15463	16322	20102	22164	25772	30926
Pressure drop system side	kPa	43	39	35	44	37	41	44	49	58	75

(1) Data 14511:2018; System side water heat exchanger 12 °C/7 °C; External air 35 °C

NRL - C

Size		0280	0300	0330	0350	0500	0550	0600	0650	0700	0750
Model: C											
Cooling performance 12 °C / 7 °C (1)											
Cooling capacity	A	kW	-	-	-	101,0	107,0	133,0	147,0	168,0	201,0
	E	kW	59,0	67,0	76,0	85,0	93,0	98,0	121,0	133,0	155,0
Input power	A	kW	-	-	-	30,5	34,5	40,5	45,0	52,8	62,5
	E	kW	17,0	19,6	22,0	25,3	33,4	37,0	44,7	52,1	57,1
Input current	A	A	-	-	-	56,0	61,0	72,0	78,0	91,0	110,0
	E	A	35,0	39,0	43,0	49,0	71,0	65,0	79,0	90,0	98,0
EER	A	W/W	-	-	-	3,31	3,10	3,28	3,27	3,18	3,22
	E	W/W	3,47	3,42	3,45	3,36	2,78	2,65	2,71	2,55	2,71

(1) Evaporating temperature 5 °C, External air 35 °C

ENERGY INDICES (REG. 2016/2281 EU)

Size		0280	0300	0330	0350	0500	0550	0600	0650	0700	0750
SEER - 12/7 (EN14825:2018) with standard fans (1)											
SEER	A	W/W	-	-	-	- (2)	- (2)	- (2)	- (2)	- (2)	- (2)
	E	W/W	- (2)	- (2)	- (2)	- (2)	- (2)	- (2)	- (2)	- (2)	- (2)
SEER - 23/18 (EN14825: 2018) with standard fans (3)											
SEER	A	W/W	-	-	-	4,34	4,19	4,73	4,71	4,59	4,57
	E	W/W	4,55	4,70	4,62	4,47	4,32	4,18	4,67	4,61	4,50
Seasonal efficiency	A	%	-	-	-	170,7%	164,6%	186,2%	185,2%	180,5%	179,9%
	E	%	178,9%	184,9%	181,6%	175,9%	169,7%	164,0%	183,8%	181,3%	177,2%
SEPR - (EN14825: 2018) High temperature with standard fans (3)											
SEPR	A	W/W	-	-	-	6,05	5,66	5,94	5,91	5,74	5,74
	E	W/W	5,81	5,94	5,85	5,66	5,62	5,34	5,76	5,71	5,54

(1) Calculation performed with FIXED water flow rate and VARIABLE outlet temperature.

(2) Not covered by standard (EN14825: 2018 for comfort applications, 12 °C / 7 °C)

(3) Calculation performed with FIXED water flow rate.

ELECTRIC DATA

Size		0280	0300	0330	0350	0500	0550	0600	0650	0700	0750
Electric data											
Maximum current (FLA)	A	A	-	-	-	76,0	81,0	100,0	112,0	122,0	320,0
	E	A	46,0	53,0	58,0	63,0	76,0	76,0	100,0	112,0	144,0
Peak current (LRA)	A	A	-	-	-	214,0	220,0	232,0	243,0	261,0	144,0
	E	A	155,0	184,0	190,0	200,0	214,0	214,0	232,0	243,0	320,0

GENERAL TECHNICAL DATA

Size			0280	0300	0330	0350	0500	0550	0600	0650	0700	0750		
Compressor														
Type	A,E	type							Scroll					
Compressor regulation	A,E	Type							On-Off					
Number	A,E	no.	2	2	2	2	3	3	4	4	4	4		
Circuits	A,E	no.	2	2	2	2	2	2	2	2	2	2		
Refrigerant	A,E	type							R410A					
System side heat exchanger														
Type	A,E	type							Brazed plate					
Number	A,E	no.	1	1	1	1	1	1	1	1	1	1		
System side hydraulic connections														
Connections (in/out)	A,E	Type							Grooved joints					
Sizes (in/out)	A,E	Ø	2" 1/2	2" 1/2	2" 1/2	2" 1/2	2" 1/2	2" 1/2	2" 1/2	2" 1/2	2" 1/2	3"		
Fan														
Type	A	type	-	-	-	-	Axial	Axial	Axial	Axial	Axial	Axial		
	E	type							Axial					
Fan motor	A	type	-	-	-	-	Asynchronous with phase cut	Asynchronous with phase cut	Asynchronous with phase cut	Asynchronous with phase cut	Asynchronous with phase cut	Asynchronous with phase cut		
	E	type	Inverter	Inverter	Inverter	Inverter	Asynchronous with phase cut	Asynchronous with phase cut	Asynchronous with phase cut	Asynchronous with phase cut	Asynchronous with phase cut	Asynchronous with phase cut		
Number	A	no.	-	-	-	-	2	2	2	2	3	3		
	E	no.	6	6	8	8	2	2	2	2	3	3		
Air flow rate	A	m ³ /h	-	-	-	-	34100	34100	32600	32600	50000	49000		
	E	m ³ /h	22000	22000	27000	27000	21100	22200	21800	22800	32500	35300		
Sound data calculated in cooling mode (1)														
Sound power level	A	dB(A)	-	-	-	-	82,0	82,0	82,0	83,0	85,0	85,0		
	E	dB(A)	74,0	74,0	75,0	76,0	74,0	74,0	74,0	74,0	77,0	77,0		
Sound pressure level (10 m)	A	dB(A)	-	-	-	-	50,1	50,1	50,1	51,1	53,0	52,9		
	E	dB(A)	42,3	42,2	43,2	44,2	42,1	42,1	42,1	42,1	45,0	45,0		

(1) Sound power calculated on the basis of measurements made in accordance with UNI EN ISO 9614-2, as required for Eurovent certification. Sound pressure (cold functioning) measured in free field, 10m away from the unit external surface (in compliance with UNI EN ISO 3744).

DIMENSIONS

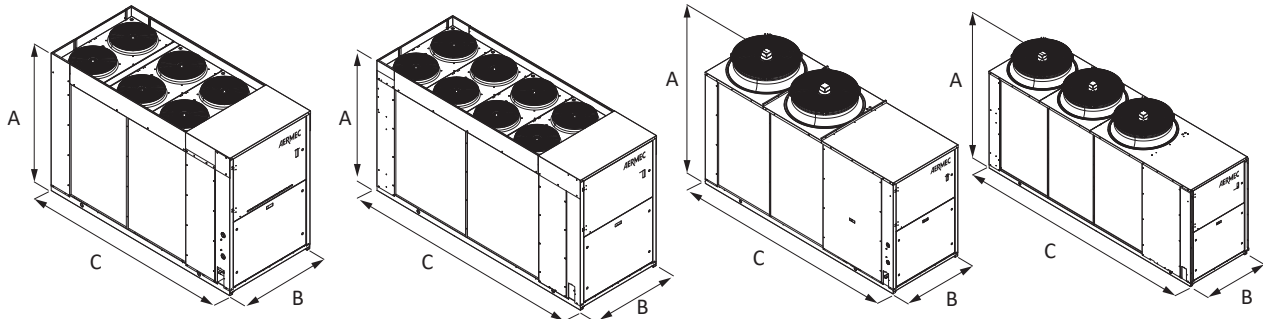

Size			0280	0300	0330	0350	0500	0550	0600	0650	0700	0750
Dimensions and weights												
A	A	mm	-	-	-	-	1875	1875	1875	1875	1875	1975
	E	mm	1606	1606	1606	1606	1875	1875	1875	1875	1875	1975
B	A	mm	-	-	-	-	1100	1100	1100	1100	1100	1500
	E	mm	1100	1100	1100	1100	1100	1100	1100	1100	1100	1500
C	A	mm	-	-	-	-	3010	3010	3010	3010	4010	4350
	E	mm	2450	2950	2950	2950	3010	3010	3010	3010	4010	4350
Dimensions and weights without hydronic kit												
Empty weight	A	kg	-	-	-	-	955	959	1142	1155	1323	1663
	E	kg	686	751	761	767	955	959	1142	1155	1323	1663

Aermec reserves the right to make any modifications deemed necessary. All data is subject to change without notice. Aermec does not assume responsibility or liability for errors or omissions.

Aermec S.p.A.
Via Roma, 996 - 37040 Bevilacqua (VR) - Italia
Tel. 0442633111 - Telefax 044293577
www.aermec.com