

CMP

Monobloc without outdoor unit

Cooling capacity 2,35 kW
Heating capacity 2,36 kW

- Two holes, no outdoor units.
- Modern design to blend with all furnishing styles.
- Extremely thin, with a depth of just 165 mm.



DESCRIPTION

The air-conditioners of the CMP range are of the single-block type and are ideal for heating, cooling, dehumidification or ventilation only, whether in the home or the office.

The absence of an outdoor unit permits installation in all those cases where architectural restraints prevent the positioning of a split air-conditioner.

The unit boasts a compressor and a fan with inverter technology.

FEATURES

Unit

Indoor unit designed for installation on internal walls.

- No need for an outdoor unit just make two 162 mm holes in the outer wall so the air-conditioner can exchange heat with the external environment.
- Folding grilles included.
- On-board control panel with display and soft-touch keys.
- Included remote control.

Cooling operation with outside temperatures up to 35 °C.

Heating operation with outdoor temperatures down to 7 °C.



Folding grilles

With two folding grilles which, activated by the inlet and outlet air, open when the machine is working and close when the machine is switched off.

In this way they guarantee enhanced indoor comfort, less dust, noise and pollution, reduced maintenance and are even less visible from the outside.

Control panel

The on-board control panel with display and soft-touch keys allows you to set the required temperature set-point easily and accurately.

The "heating" function is deactivated by a simple intervention on the control panel: the device then works in "cooling only" mode, without requiring the condensate discharge tube.

The air delivery fin is easily orientated by means of the relative key.

Remote control

Handy remote control that's not too bulky.

Fitted with a practical magnet so it can be fixed to the unit.

All the control panel functions are available via the remote control too.

GENERAL FEATURES

- Condensate drip tray constantly pre-heated in the winter during heat pump operation, without any risk of the water freezing.
- Operating mode: cooling, dehumidification and fan only.
- Particularly quiet operation.
- Microprocessor control.

ACCESSORIES AS STANDARD

- Condensate drip.
- Two folding grilles.
- Remote control.

PERFORMANCE SPECIFICATIONS

CMP23I		
Nominal cooling performances		
Cooling capacity (1)	kW	2,35
Cooling input power (1)	kW	0,73
EER (2)	W/W	3,22
Maximum cooling performances		
Cooling capacity	kW	3,10
Nominal cooling performances		
Moisture removed	l/h	1,1
Seasonal efficiency		
Efficiency energy class (3)		A+
Annual power consumption	kWh/annum	425
Nominal heating performances		
Heating capacity (4)	kW	2,36
Heating input power (4)	kW	0,72
COP (2)	W/W	3,28
Maximum heating performances		
Heating capacity	kW	3,05
Seasonal efficiency (temperate climate)		
Efficiency energy class (3)		A

(1) Cooling (EN-14511 and EN-14825) ambient air temperature 27 °C D.B. / 19 °C W.B.; outside air temperature 35 °C; max speed; length of refrigerant lines 5 m.

(2) EER/COP in accordance with the Standard (EN-14511), only declared for the purposes of the tax deductions in force at the time of this publication.

(3) Data in accordance with Delegated Regulation (EU) No. 626/2011.

(4) Heating (EN-14511 and EN-14825) ambient air temperature 20 °C D.B.; outside air temperature 7 °C D.B. / 6 °C W.B.; max speed; length of refrigerant lines 5 m.

GENERAL DATA

CMP23I		
Fan		
Type	type	Inverter centrifugal
Number	no.	1
Inner side air flow rate		
Maximum	m ³ /h	400
Average	m ³ /h	320
Minimum	m ³ /h	270
Outer side air flow rate		
Maximum	m ³ /h	480
Average	m ³ /h	390
Minimum	m ³ /h	340
Compressor		
Number	no.	1
Refrigerant	type	R410A
Refrigerant charge	kg	0,6
Potential global heating	GWP	2088kgCO ₂ eq
Sound data calculated in cooling mode (1)		
Sound power level	dB(A)	58,0
Sound pressure level (1,5 m)	dB(A)	46,0

(1) Sound power calculated on the basis of measurements made in accordance with UNI EN ISO 9614-2, as required for Eurovent certification. Sound pressure (cold functioning) measured in free field, 10m away from the unit external surface (in compliance with UNI EN ISO 3744).

DIMENSIONS AND WEIGHTS

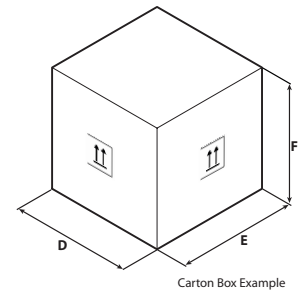
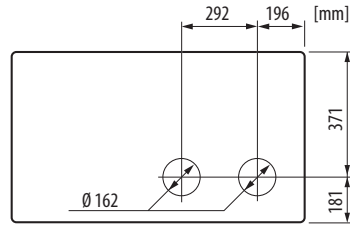
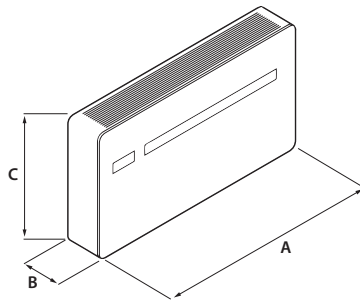

Carton Box Example

CMP231

Dimensions and weights

A	mm	1030
B	mm	170
C	mm	555
D	mm	1100
E	mm	260
F	mm	660
Net weight	kg	48
Weight for transport	kg	49

Aermec reserves the right to make any modifications deemed necessary.
All data is subject to change without notice. Aermec does not assume responsibility or liability for errors or omissions.

Aermec S.p.A.
Via Roma, 996 - 37040 Bevilacqua (VR) - Italia
Tel. 0442633111 - Telefax 044293577
www.aermec.com